

STEPPER MOTOR DRIVER

CW230 2-Phase Microstepping Motor Driver

Characteristics:

- 1.DC power input type 24V~36V
- 2.Output current: 0.9~3A
- 3.Microstep: 1(1.8°), 1/2, 1/4, 1/8, 1/16, 1/32, 1/64
- 4.Protect form : Overheated protect, lock automatic half current , error connect protect
- 5.Dimension: 115mm*72mm*32mm
- 6.Weight: <300g.
- 7.Working environment: Temperature -15~40°C Humidity <90%.
- 8.

I/O Ports:

- 1.VCC+DC power positive pole

Note: Must guard against exceeding 40V,
so as not to damage the module

- 2.GND: DC power cathode

- 3.A+,A-: Stepping motor one winding

- 4.B+,B-: Stepping motor other winding

- 5.CP +,CP -: Stepping pulse input +5V (Rising edge effective ,
rising edge duration >10μS)

- 6.CW +,CW -: Stepping motor direction input, voltage level touched
off, high towards, low reverse

- 7.REST+,REST-: motor free

The interface see
the right picture

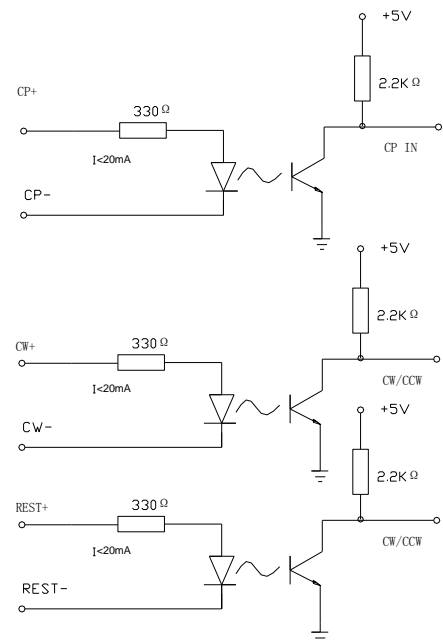

NOTE:

1. When ambient temperature is high or working current over 2A, fix the module on big metal shell , or use axle flows fan dispels the heat, to make the module run reliably for a long time.
2. Half current automatically: if control machine not send out signal in half second, driver enter half current state of automatically for electricity saving, the phase current of the winding of the electric.
3. The fault phase is protected : When the double-phase electrical machinery is connected with driver , users are apt to connect the phase by mistake, thus would damage the driver seriously. The protecting circuit is within this driver, when users connect by mistake, the driver will not be damaged, but the electrical machinery runs abnormally, shake , and output is small. Please check whether the wiring of electrical machinery is a mistake.

STEPPER MOTOR DRIVER

CW230 2-Phase Mircostepping Motor Driver

Switch Choice: ("ON=0, OFF=1")

1. Microstep choice

M1	1	0	1	0	1	0	1	0
M2	1	1	0	0	1	1	0	0
M3	1	1	1	1	0	0	0	0
Micro	1	1/2	1/4	1/8	1/16	1/32	1/64	—

2. Current choice:

M5	0	0	0	0	1	1	1	1
M6	0	0	1	1	0	0	1	1
M7	0	1	0	1	0	1	0	1
Current (A)	0.9	1.2	1.5	1.8	2.1	2.4	2.7	3

Dimension:(mm)

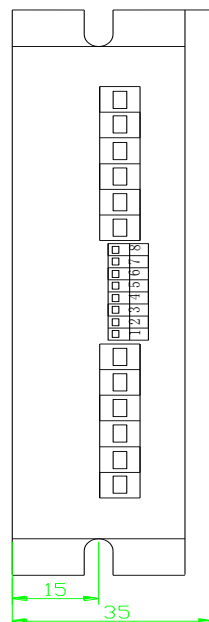
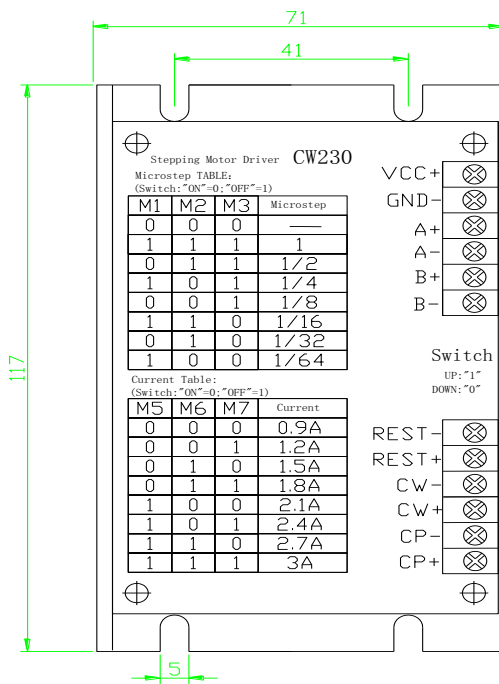

CW230 2-Phase
Mircostepping Motor
Driver

Photo for CW230

STEPPER MOTOR DRIVER

